

NOTES

1. THERE IS A _____ UTILITY AND DRAINAGE EASEMENT ALONG EACH SIDE OF ALL SIDE PROPERTY LINES, AND A _____ EASEMENT ALONG EACH SIDE OF REAR PROPERTY LINES.

REVISIONS AND RECERTIFICATIONS

NO.	BY	DATE	DESCRIPTION	JOB NO. REFERENCE	APP.
1					
2					
3					
4					

REFERENCES

BB	DB	PB
BB	DB	PB
BB	DB	PB
BB	DB	PB

LOCATION MAP

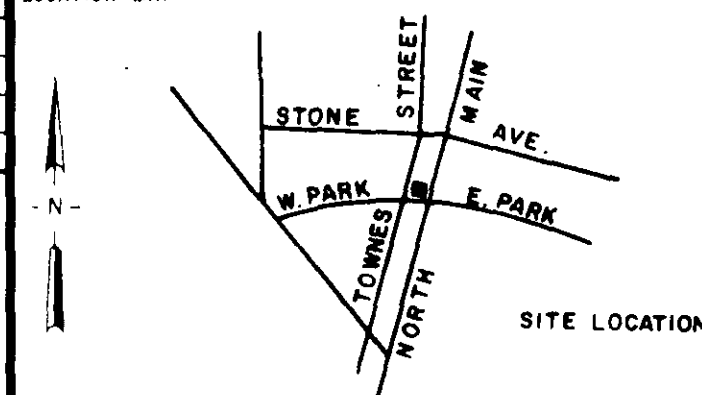

CERTIFICATION

THIS IS TO CERTIFY TO EUGENE C. GARVIN, JR. THAT AN ACTUAL FIELD SURVEY WAS PERFORMED ON THIS PROPERTY UNDER MY SUPERVISION AND I DECLARE THAT:
 (1) THE FIELD SURVEY AND THIS PLAT REPRESENT A DEPENDENT RESURVEY OF THE SUBJECT PROPERTY AND THAT THE INFORMATION SHOWN HEREON IS CORRECT TO THE BEST OF MY PROFESSIONAL KNOWLEDGE AND BELIEF.
 (2) ALL RIGHTS OF WAY, EASEMENTS AND ENCROACHMENTS, OBVIOUS AND APPARENT FROM FIELD OBSERVATION OF THE SUBJECT PROPERTY AT THE TIME OF THE SURVEY ARE AS SHOWN.
 (3) THE AREA OF THE SUBJECT PROPERTY WAS CALCULATED BY COORDINATES AND THAT THIS IS A CLASS B SURVEY.

William N. Clark
 SIGNATURE OF REGISTERED LAND SURVEYOR DATE 5/10/84 S.C. REG. NO. 7261

THIS IS TO CERTIFY TO _____ THAT THIS DRAWING IS A COMPOSITE PLAT AND DOES NOT CONSTITUTE AN ACTUAL FIELD SURVEY, AND THAT ANY USE OF THIS DRAWING FOR ANY PURPOSE OTHER THAN GENERAL REFERENCE IS DONE SO WITH THE UNDERSTANDING THAT ARBOR ENGINEERING INC. ASSUMES NO RESPONSIBILITY OR LIABILITY FOR ITS ACCURACY OR CORRECTNESS.

SIGNATURE OF REGISTERED LAND SURVEYOR _____ DATE _____ S.C. REG. NO. _____

THE DEPARTMENT OF HOUSING AND URBAN DEVELOPMENT FLOOD WAY DATA FOR GREENVILLE COUNTY SHOWS THIS PROPERTY TO BE IN A FLOOD PLAIN AREA NOT TO BE IN A FLOOD PLAIN AREA LOCATION CANNOT BE DETERMINED.

**PROPERTY SURVEY FOR
EUGENE C. GARVIN, JR.**

**UNIT 23 BUILDING D
HERITAGE PARK**

GREENVILLE SOUTH CAROLINA

SCALE 10 0 10 20

RESEARCH	N/A	DRAWN	WNS	CHECK	WNS	DATE	1 MAY 84
FILE		FIELD WORK BY		JOB NO.	83115-01		

ARBOR ENGINEERING
 P.O. BOX 263, GREENVILLE, S.C.
 LANDSCAPE ARCHITECTS-ENGINEERS-LAND SURVEYORS

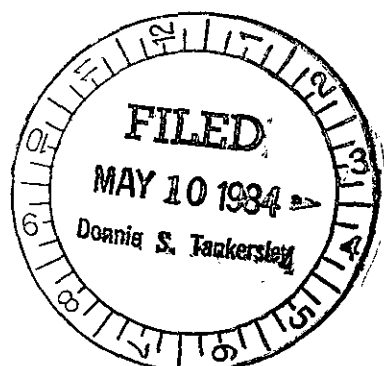
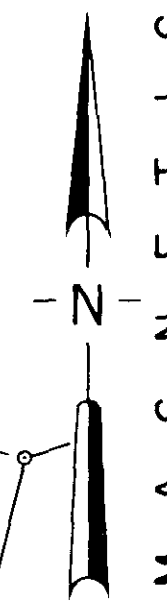
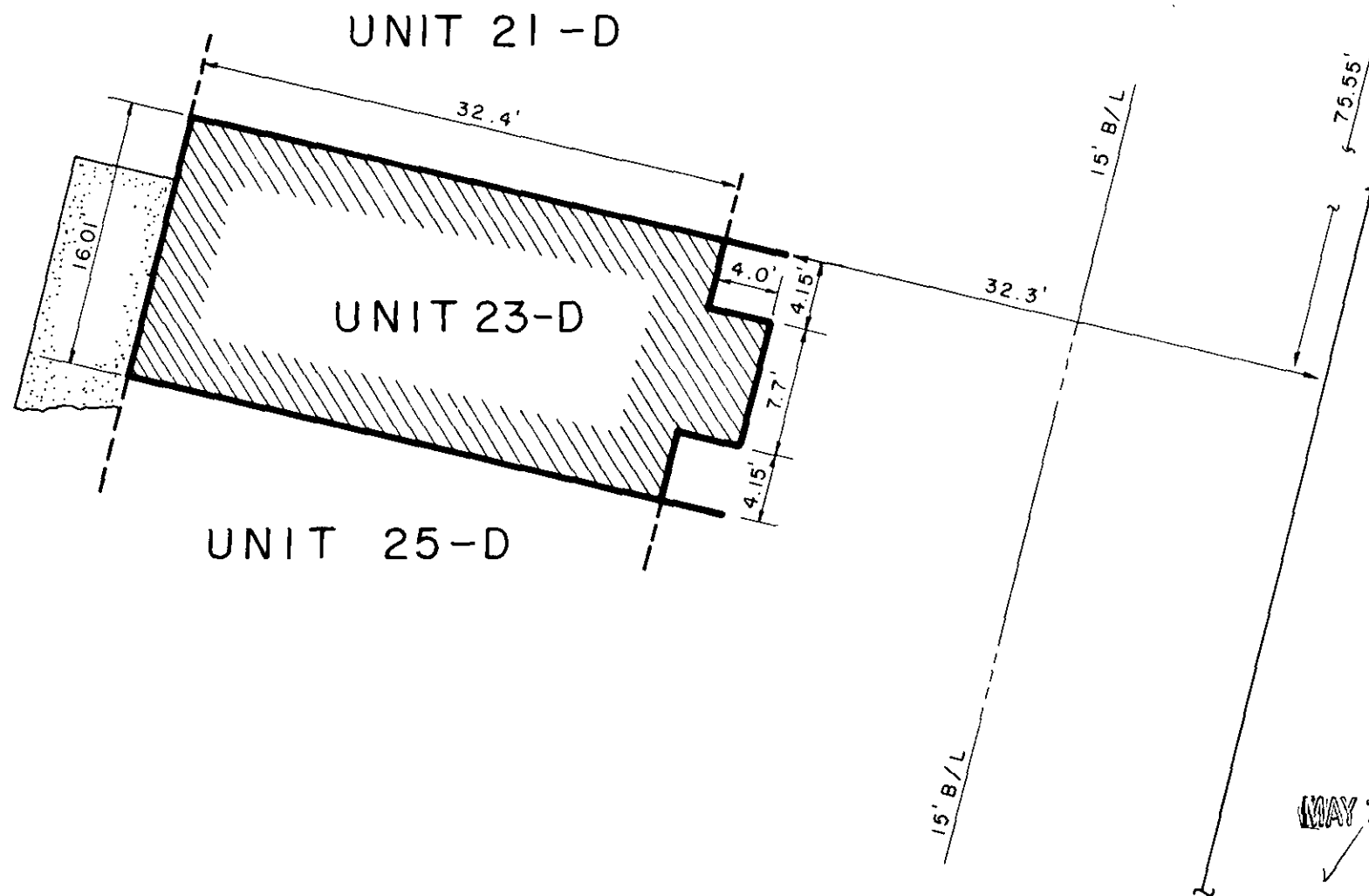

MAY 10 1984
 35393

10-N-76

THE PRINT MACHINE, INC. N28693

MICROFILMED