



**Greenville
County**

Single Family Residential Erosion/Sediment Control Standards



Revised March 2023

PAGE INTENTIONALLY LEFT BLANK

Single Family Residential Erosion/Sediment Control Standards

Table of Contents

INTRODUCTION	4
RESIDENTIAL EROSION AND SEDIMENT CONTROL REQUIREMENTS	5
OWNER/PERMIT HOLDER/CONTRACTOR RESPONSIBILITIES	6
BEST MANAGEMENT PRACTICES (BMPS)	7
INSPECTION	8
SINGLE FAMILY LOT EROSION CONTROL PLAN - TYPE A	9
SINGLE FAMILY LOT EROSION CONTROL PLAN - TYPE B	10
SINGLE FAMILY LOT EROSION CONTROL PLAN - TYPE C	11
TEMPORARY CONSTRUCTION ENTRANCE PLAN	12
SC-06 CONSTRUCTION ENTRANCE	13
SC-03A SILT FENCE	14
SEDIMENT FENCE - MINIMUM REQUIREMENTS AND INSTALLATION	16
PERIMETER CONTROL FOR SMALL SITES	17
SC-12 PERIMETER CONTROL FOR SMALL SITES	18
SC-04 ROCK DITCH CHECK	20
SC-07 STORM DRAIN INLET PROTECTION	22
SC-14 CONCRETE WASHOUT	24
EC-03 SEEDING/STABILIZATION	26

Introduction

This booklet contains standard plans and procedures sufficient for typical residential land disturbing activities, though it is not intended to address all circumstances.

All projects that will involve land disturbing activities (e.g. clearing, grading or grubbing) must provide erosion and sediment control measures to prevent the concentration of stormwater runoff and the transport of sediment from the site to storm drains, surface waters, wetlands, adjacent properties, and roadways. Roadways are conduits for stormwater and it is important to keep them sediment and debris free. The primary goal is perimeter control with best management practices (BMP's) being utilized to prevent erosion and minimize off-site sediment impact.

The Permit Holder is responsible for ensuring that adequate BMP's are in place and functioning as designed until the site is stabilized.

When making the determination if lot-to-lot protection is necessary always keep in mind the intent of the standard; and that is **to prevent erosion and minimize sediment from leaving the site**. Failure to do so may result in damage to adjacent property and/or to the storm drain system, and possibly contribute to sediment and pollutants entering surface waters. If any questions or concerns arise, please contact Greenville County's Land Development Division (LDD) at 864-467-4610.

NOTE: IF THIS PARCEL CONTAINS A FRESHWATER WETLAND OR A CREEK THIS HANDBOOK IS NOT ACCEPTABLE FOR LAND DISTURBANCE PERMITTING. PLEASE VISIT THE LDD OFFICE IN SUITE 3900 TO OBTAIN A PERMIT FOR THIS SITE. IF WETLANDS ARE FOUND ON THIS SITE DURING OUR INSPECTIONS, AND THE APPROPRIATE PERMITS HAVE NOT BEEN OBTAINED, VIOLATIONS AND FINES WILL APPLY.



RESIDENTIAL EROSION AND SEDIMENT CONTROL REQUIREMENTS

In order to comply with the requirements imposed by the National Pollutant Discharge Elimination System (NPDES) Permit issued to Greenville County by the South Carolina Department of Health and Environmental Control (SCDHEC) and the Environmental Protection Agency (EPA), Greenville County has adopted a comprehensive Stormwater Ordinance to manage certain pollutants generated from construction sites.

LDD is responsible for the coordination and oversight of all stormwater related activities as outlined in the Stormwater Ordinance by the issuance of Land Disturbance (Grading) Permits. All land disturbing activities that result in a change in the natural cover or topography must utilize BMP's to prevent violations of the Federal Clean Water Act. All land disturbing activities are subject to permitting requirements.

Residential permitting will fall into one of the categories below:

- ▶ If the lot is part of a subdivision platted after 2003, land disturbing activity may be covered under an active permit for that subdivision. All construction activity must comply with erosion control plans for individual lots as shown on the subdivision's storm water management and sediment control plan. BMP's must be installed and maintained as outlined in this booklet. Failure to install or maintain such measures will result in a Stop Work Order and Notice of Violation. If the site continues to produce off-site impacts a Land Disturbance (Grading) permit may be required. LDD reserves the right to require a licensed design professional to oversee the project. Fines of up to \$7,500.00/ violation/day may be imposed if the site becomes a habitual offender.

- ▶ For individual lots not located within a permitted subdivision and **disturbing more than 5,000 ft but less than 1 acre** the LDD will allow the building permit to act in the place of a separate Land Disturbance (Grading) Permit; therefore, a separate Land Disturbance (Grading) Permit is not required. However, BMP's must be installed and maintained as outlined in this booklet. Failure to install or maintain such measures will result in a Stop Work Order and Notice of Violation. If the site continues to produce off-site impacts a Land Disturbance (Grading) permit may be required. LDD reserves the right to require a licensed design professional to oversee the project. Fines of up to \$7,500.00/violation/day may be imposed if the site becomes a habitual offender.

Residential lots disturbing 1 acre of land or more and not part of a larger common plan of development will be required to obtain a Land Disturbance (Grading) Permit, as well as submit a Notice of Intent (NOI) and any applicable fees to South Carolina Department of Health and Environmental Control (SCDHEC) for coverage under the Construction General Permit. LDD reserves the right to require a licensed design professional to oversee the project.

OWNER/PERMIT HOLDER/CONTRACTOR RESPONSIBILITIES

1. The Permit Holder is responsible for the correct installation and on-going maintenance of all lot specific erosion and sediment control devices.
2. Periodic inspections of the site shall be conducted as necessary to ensure that erosion and sediment control measures are functioning as designed. In addition to periodic inspections, state law and the Greenville County Stormwater Ordinance requires that a inspection be conducted within 24 hours after the end of a rain event greater than or equal to ½". Any problems noted during these inspections shall be corrected immediately.
3. Once construction has commenced, the Permit Holder is responsible for inlet protection on their lots, as well as curb inlets along the street. It is critical that sediment not be allowed to invade the stormwater system.
4. The Permit Holder is responsible for the installation, maintenance, and upkeep of stabilized construction entrance. A stabilized construction entrance is an area of aggregate underlain with geo textile material located at any point where traffic will be entering/exiting the construction site. The purpose of the stabilized construction entrance is to reduce or eliminate sediment and/or debris being tracked onto roadways. If sediment and/or debris migrates into the roadway the contractor shall take immediate steps to have it removed. Instruction and illustration details on stabilized construction entrances can be found on pages 12 and 13 of this booklet.
5. The Permit Holder is responsible for the actions of all sub-contractors and delivery personnel at the worksite as they relate to stormwater and erosion control. Establishing appropriate places for staging and the storage of building materials and paint is required. A wash out area is needed for "wet" construction materials (e.g. paint and concrete).
6. The Permit Holder is responsible for all off-site impacts. These impacts include, but are not limited to mud, dirt, debris, and trash leaving the site by means of wind, water, humans, or machinery. Should any off-site impacts occur, the Permit Holder is responsible for mitigating the situation immediately.
7. Erosion and sediment control measures must remain in place and properly maintained throughout the construction period. The site must be vegetated or otherwise stabilized before the measures can be removed.

BEST MANAGEMENT PRACTICES (BMPs)

Inlet Protection - Ensure that the BMPs are in place and functioning for both area inlets and curb inlets along the street frontage.

Protection of Adjacent Lots - Install BMPs along the common lot line of adjacent undisturbed lots.

Temporary Construction Entrance - Prior to any delivery of material or construction of any kind, a stabilized construction entrance shall be installed.

Grading/Excavation - Install all BMPs prior to excavation, where practical.

Stabilized Stockpiles - Install BMPs to stabilize stockpiles to prevent off- site impacts.

Backfill - Complete installations of all BMPs per the specified design.

Maintenance - The Permit Holder is responsible for maintaining and repairing all BMPs as necessary to ensure no off-site impacts occur.

Final Grading - BMPs may be removed in order to complete final grading and stabilization. BMPs must be maintained until 70% of the disturbed area is stabilized.



INSPECTION

1. For permitted projects, LDD personnel will check erosion and sediment control measures with routine inspections within the subdivision. Inspections will ensure the proper placement and that the erosion and sediment control measures are functioning as intended.
2. The Building Codes Inspector will also review the site during the course of scheduled inspections. If BMP's are not maintained the inspector will report all violations to the LDD Inspection staff. The LDD Inspector may issue a Stop Work Order and a Notice of Violation.
3. Minor corrections to erosion and sediment control measures must be completed within 24 hours. If corrections are not completed within that time frame, a Stop Work Order will be posted and a Notice of Violation issued. A fee will be assessed to release the stop work order and fines not to exceed \$7,500.00/violation/day may be assessed if the site or the builder/contractor becomes a habitual offender.



SINGLE FAMILY LOT EROSION CONTROL PLAN - TYPE A

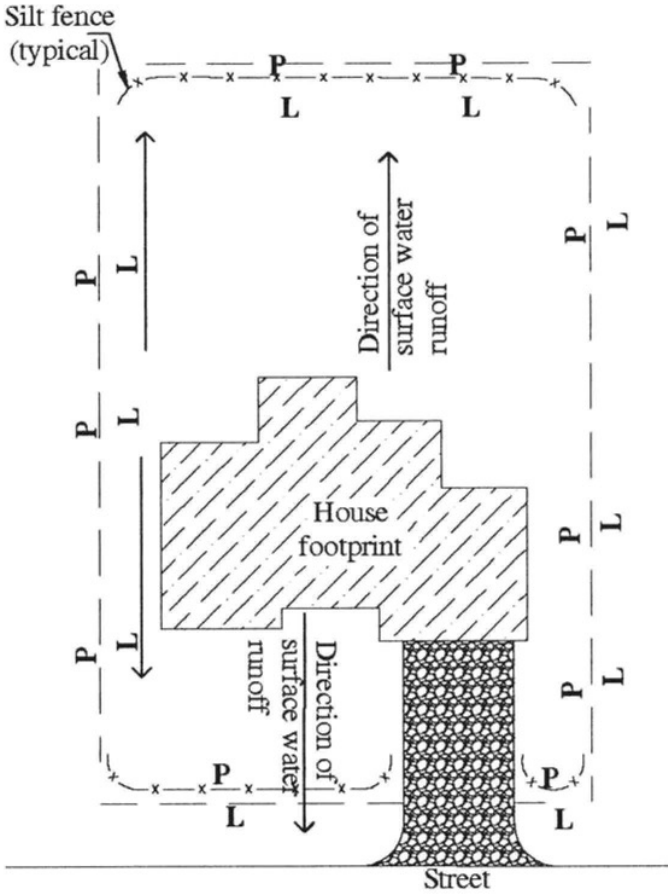

- x-x- Silt fence
- Gravel construction entrance
- ← Direction of surface water runoff

SINGLE FAMILY LOT EROSION CONTROL PLAN - TYPE B

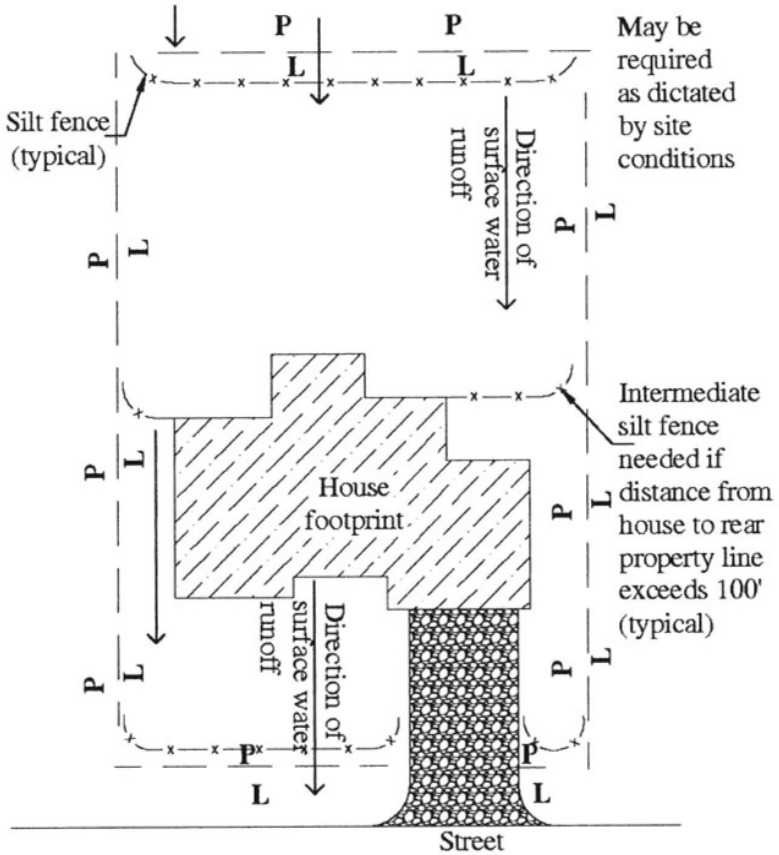

- x - x - Silt fence
- Gravel construction entrance
- ← Direction of surface water runoff

SINGLE FAMILY LOT EROSION CONTROL PLAN - TYPE C

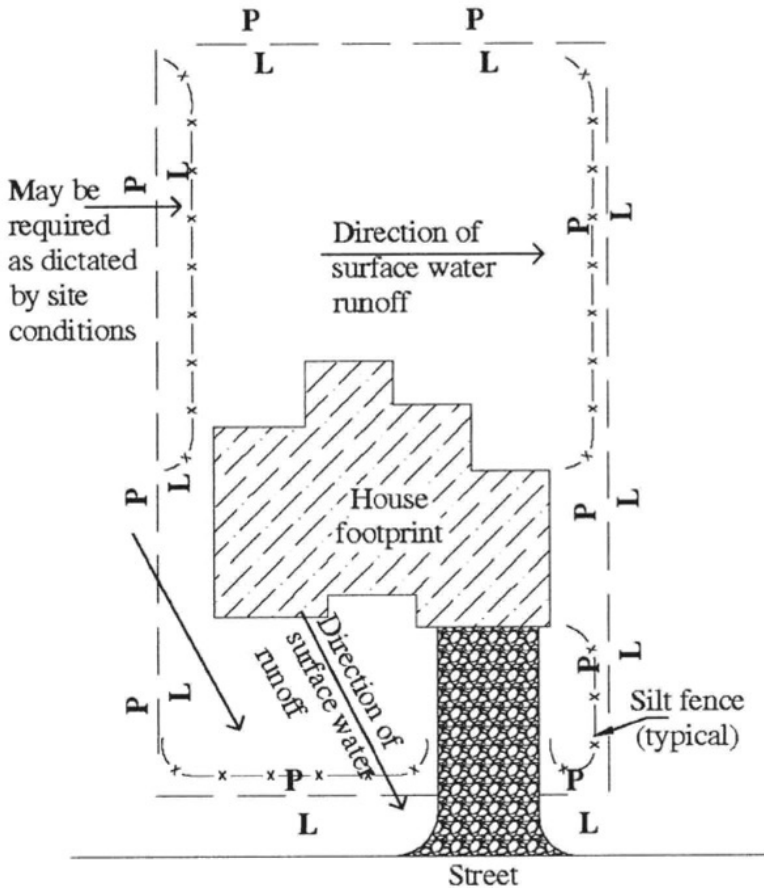

-x-x- Silt fence

 Gravel construction entrance

← Direction of surface water runoff

TEMPORARY CONSTRUCTION ENTRANCE PLAN

Temporary Construction Entrance

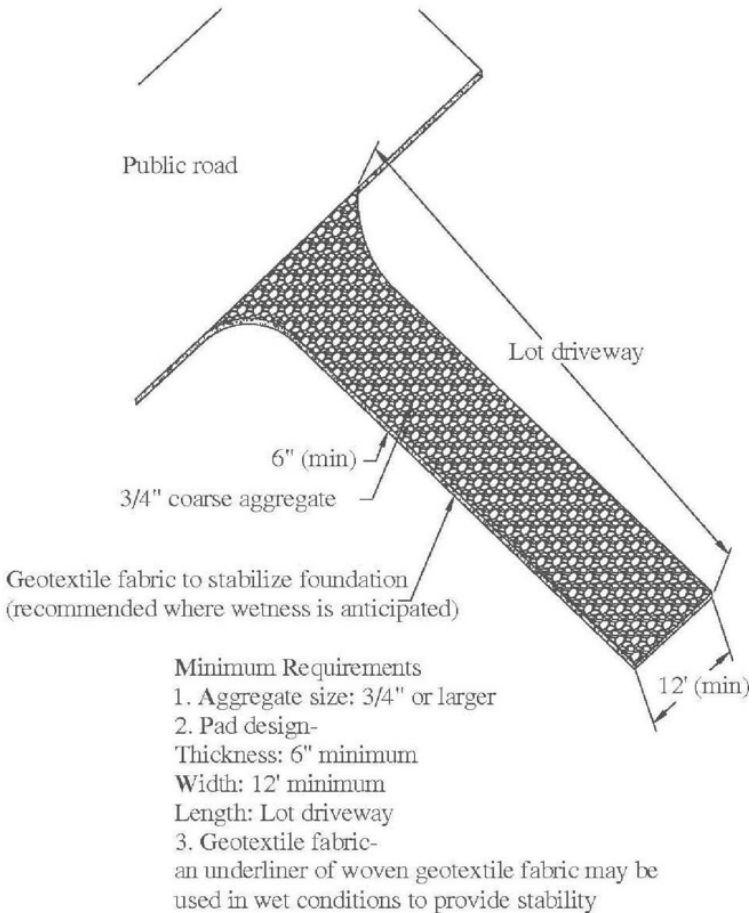

SC-06 CONSTRUCTION ENTRANCE

GOOD - note of 1.5" - 3" stone, not #57 stone



WRONG - no filter fabric under stone and maintenance overdue



SC-03A SILT FENCE

GOOD - steel posts at 6' spacing

Install OK but sediment storage quickly full, needs better upstream BMPs



SC-03 DOUBLE ROW SILT FENCE

GOOD - double row silt fence should be spaced 3-5 feet apart

WRONG - fabric not trenched in, double rows are too close



SPECIFICATIONS FOR SEDIMENT FENCE FABRIC

Physical Property	Minimum Requirement
Filtering Efficiency	80%
Tensile Strength	90 pounds/linear inch
Ultraviolet Stability	70%

1.25 LB./LINEAR FT. STEEL POSTS

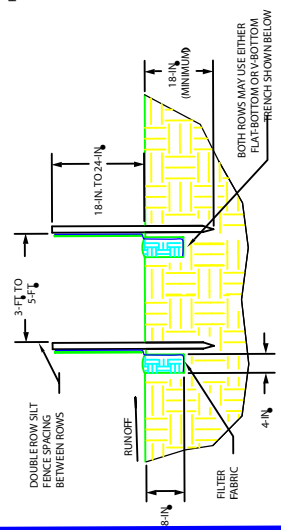

DOUBLE ROW SILT FENCE DETAIL

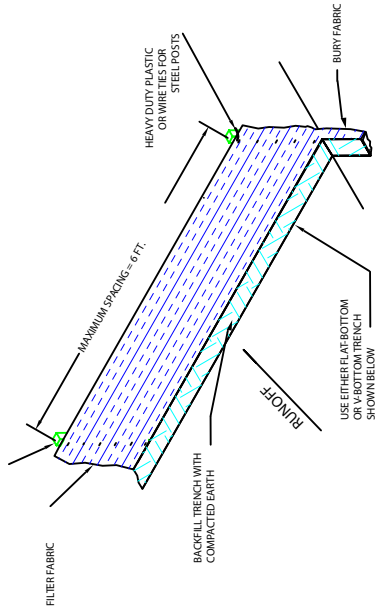

SILT FENCE INSTALLATION

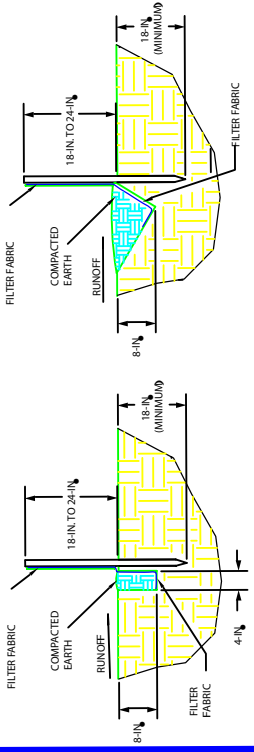

FLAT-BOTTOM TRENCH DETAIL

V-SHAPED TRENCH DETAIL



Greenville County
Storm Water Management

STANDARD DRAWING NO.	SC-03A
DATE	March, 2010
APPROVED BY	GREENVILLE COUNTY WATER MANAGEMENT

SEDIMENT FENCE - Minimum Requirements and Installation

Overland Slope Length - Maximum of 100'. Flare ends of fence uphill to temporarily impound water.

Spacing of support posts - Drive posts at least 18" into the ground on the downslope side of the trench. Space posts a maximum of 6' on center. Attach a continuous length of fabric to upslope side of fence posts. Minimize the number of joints. Avoid joints at low points in the fence line. Overlap, do not abut, ends of fabric.

Trench - Dig trench at least 4" wide and 8" deep along the fence alignment. Bottom 1' of fence must be buried a minimum of 8" deep lapping 4" toward the upslope side and covered by compacted backfill.

Impounded water height - Depth of impounded water should not exceed 1.5' at any point along fence. Do not place silt fence in areas of concentrated flow.

Sediment depth – Sediment must be removed when it reaches approximately 1/3 height of the fence.

Support posts - 1.25 Lb/linear foot steel. Steel posts should have projections for fastening fabric.

Support wire – Support wire fence (14-gauge with 6" mesh) is necessary if contributing slope is greater than 3%. Fasten support wire fence to upslope side of posts, extending 6" into trench.

Synthetic geotextile fabric - Conforming to specifications in Table 1 and containing ultraviolet light inhibitors and stabilizers. Maximum design life of 6 months. Attach fabric to steel posts using heavy-duty plastic or wire ties that are evenly spaced. Affix ties no less than 4 places spaced a maximum of 6" apart.

Maintenance - Inspect silt fence weekly and after each rainfall event of 1/2" or greater. Make necessary repairs immediately. Should the fabric of the silt fence collapse, tear, decompose or become ineffective, replace promptly.
Removal – Silt fence should be removed within 30 days after final stabilization is achieved. Disturbed areas resulting from fence removal should be permanently stabilized.

NOTE: IF BMP'S ARE DAMAGED WHEN THE UTILITIES ARE INSTALLED THE PERMIT HOLDER IS RESPONSIBLE FOR SEDIMENT AND EROSION CONTROL AS WELL AS THE REPAIR OR RE-INSTALLATION OF THE DAMAGED BMP'S.

ALWAYS INSTALL SILT FENCE PER MANUFACTURES INSTRUCTIONS

PERIMETER CONTROL FOR SMALL SITES

Sediment tubes – Sediment tubes can be used in place of a silt fence around the perimeter of relatively flat small sites (less than 1 disturbed acre) and individual single lots.

Overland slope length – The maximum length to the Perimeter Control is 100 ft.

Sediment Tube Material – Pre-installed tube diameter should be 18" to 24". 30 lb's/ft for 18" and 4 lb's/ft for 24". 10' minimum in length. Materials must be certified 100% weed free. When curled excelsior wood fiber is used, 80% of the fiber materials are a minimum of four (4) inches in length. When washed shredded recycled rubber particles are used, a minimum of 98% of metal is removed. Materials are enclosed by a tubular, flexible outer netting treated with ultraviolet stabilizers.

Do not use straw, curled excelsior wood, or natural coconut rolled erosion control products (RECPs) that are rolled up to create a sediment tube for ditch checks device. Do not use straw bales, natural pine needles, leaf mulch, and or grass clippings.

Table 1: Minimum Performance Requirements for Sediment Tubes

Property	Value
Pre-installed Tube Diameter	18.0-inch minimum 24.0-inch minimum
Mass Per Unit Length	3.0 lbs/ft +/- 10% minimum for 18-in diameter, 4.0 lbs/ft +/- 10% minimum for 24-in diameter
Length Per Tube	10-ft minimum ²

Height – Sediment tubes for Perimeter Control shall be 7" above the ground.

Trench – Dig a small U-shaped trench to a depth that is 20% of the perimeter control diameter/height. Lay the Perimeter Control flat in the U-shaped trench and compact the upstream Perimeter Control soil interface with soil.

Staking Post – Install Perimeter Control using 4' wooden posts (3/4 inch x 3/4 inch) or steel posts (1.25 lbs/ linear foot).

Spacing – Space stakes on 6-foot centers and drive them into the ground to a depth of 2 feet.

Maintenance – Inspect Perimeter Control weekly and after each rainfall event that produces 1/2-inches or greater. Check and repair, when necessary, where runoff has eroded a channel beneath the Perimeter Control, or where the Perimeter Control has sagged, undercut, or collapsed by overtopping.

Remove – Remove Perimeter Control within 30 days after final stabilization is achieved. Gather and dispose Perimeter Control in trash. Backfill all trenches, depressions, or other ground disturbances caused by the removal of Perimeter Control and then permanently stabilize disturbed areas.

SC-12 PERIMETER CONTROL FOR SMALL SITES

GOOD - non-weighted sediment tubes staked in place



Blue Sediment Tube: Good - weighted sediment tube
Hay Bales: Wrong - should not be used in place of sediment tubes



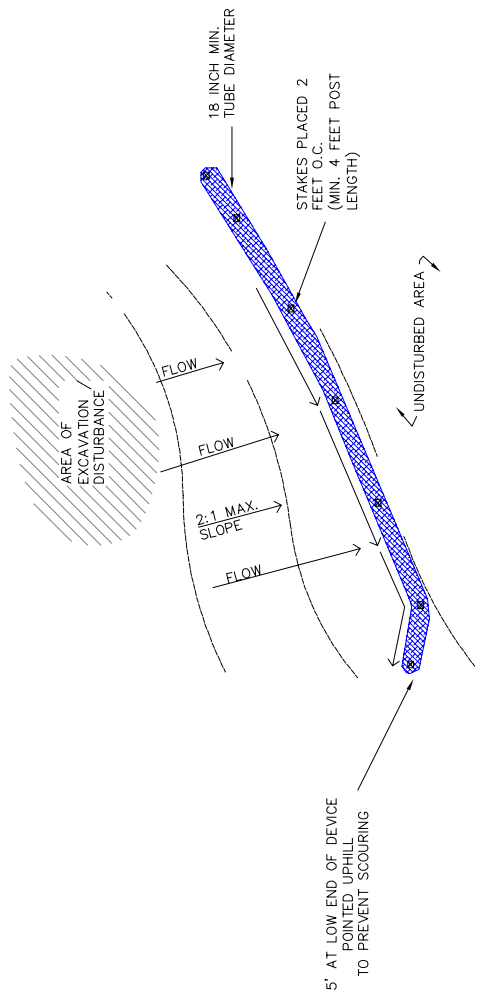

NOTES:

1. REMOVE SEDIMENT FROM THE UPSLOPE SIDE OF THE FILTER SOCK WHEN ACCUMULATION HAS REACHED $\frac{1}{2}$ OF EFFECTIVE HEIGHT OF FILTER SOCK
2. SLOPES GREATER THAN 5% MAY REQUIRE ADDITIONAL STABILIZATION PRACTICES
3. SEDIMENT TUBE MAY BE SEEDED AT THE TIME OF INSTALLATION

Greenville County Storm Water Management
 SEDIMENT TUBE FOR PERIMETER CONTROL OF SMALL SITES
 STANDARD DRAWING NO. **SC-12**
 APPROVED BY: _____ DATE: January 2018
 GREENVILLE COUNTY STORM WATER MANAGEMENT

SEDIMENT TUBE FOR PERIMETER CONTROL

SC-04 ROCK DITCH CHECK

GOOD - filter fabric under stone and washed stone on upstream face



WRONG - too large and incorrect stone, water has eroded around



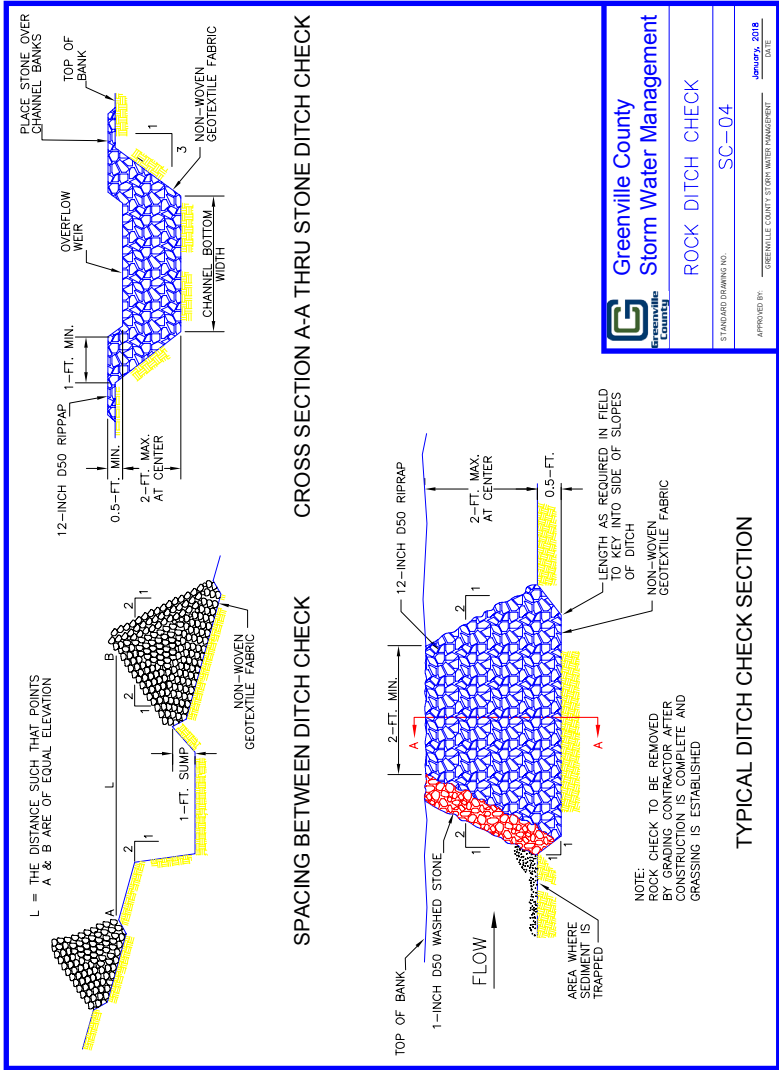

Greenville County
Storm Water Management

ROCK DITCH CHECK

SC-04

STANDARD DRAWING NO. _____
 APPROVED BY _____
 GREENVILLE COUNTY STORM WATER MANAGEMENT DEPARTMENT
 JANUARY, 2018

SC-07 STORM DRAIN INLET PROTECTION

INSTALLATION:

1. FILTER FABRIC IS USED FOR INLET PROTECTION WHEN STORM WATER FLOWS ARE RELATIVELY SMALL (1.0 CFS OR LESS) WITH LOW FLOWS WHERE THE INLET DRAINS AN AREA THAT HAS GRADES NO GREATER THAN 1%. USE IN AREAS RECEIVING CONCENTRATED FLOW IS NOT ACCEPTABLE. THIS PRACTICE CANNOT BE USED ON THE OUTER PERIMETER OF THE CONCENTRATED FLOW UNLESS FILTER FABRIC IS PNEUMATICALLY INSTALLED.
2. FILTER FABRIC WILL CONFORM TO THE STORM DRAIN INLET PROTECTION SPECIFICATION. FILTER FABRIC WILL EXTEND A MINIMUM OF 12 INCHES INTO THE TRENCH. THE TRENCH WILL BE BACKFILLED WITH SOIL OR CRUSHED STONE AND COMPACTED OVER THE FILTER FABRIC UNLESS FABRIC IS PNEUMATICALLY INSTALLED.
3. USE STEEL POSTS WITH A MINIMUM POST LENGTH OF 5 FEET CONSISTING OF STANDARD "T" SECTIONS WITH A MINIMUM OF 24 INCHES. POSTS SHALL BE SPACED AROUND THE PERIMETER OF THE INLET AND A MAXIMUM OF 2 FEET APART AND DRIVEN INTO THE GROUND A MINIMUM OF 24 INCHES. ATTACH FABRIC TO PREVENT SAGGING OR TEARING OF THE FABRIC. ATTACH AT LEAST 4 EVENLY SPACED TIES IN A MANNER TO PREVENT SAGGING OR TEARING OF THE FABRIC.
4. FILTER FABRIC SHOULD BE IN A CONTINUOUS ROLL AND CUT TO THE LENGTH OF THE PROTECTED AREA TO AVOID THE USE OF JOINTS. WHEN JOINTS ARE NECESSARY, FILTER FABRIC SHOULD BE WRAPPED SECURELY ATTACHED SUCH THAT WHEN THE POST IS DRIVEN TO THE PROPER DEPTH, THE PLATE WILL BE BELOW GROUND LEVEL FOR ADDITIONAL STABILITY.
5. EXCEPT WHEN HEAVY CLAY SOILS ARE PRESENT, ON-SITE STEEL POSTS WILL HAVE A METAL PLATE SECURELY ATTACHED SUCH THAT WHEN THE POST IS DRIVEN TO THE PROPER DEPTH, THE PLATE WILL BE BELOW GROUND LEVEL FOR ADDITIONAL STABILITY.

INSPECTION AND MAINTENANCE:

1. INSPECTIONS SHOULD BE MADE EVERY SEVEN (7) CALENDAR DAYS AND INSPECTIONS ARE RECOMMENDED IMMEDIATELY.
2. IF THE FABRIC BECOMES CLOGGED, IT WILL BE REPLACED.
3. SEDIMENT WILL BE REMOVED WHEN IT REACHES APPROXIMATELY 1/3 THE HEIGHT OF THE FILTER FABRIC. HOLE SHALL BE MADE IN THE FABRIC TO ALLOW FOR REMOVAL OF SEDIMENT. MAINTAIN THE POOL AREA PROVIDING ADEQUATE SEDIMENT STORAGE VOLUME FOR THE NEXT STORM. TAKE CARE NOT TO DAMAGE OR UNDERCUT FABRIC WHEN REMOVING SEDIMENT.
4. STORM DRAIN INLET PROTECTION STRUCTURES CAN BE REMOVED ONLY AFTER THE DISTURBED AREAS ARE PERMANENTLY STABILIZED TO PREVENT EROSION OF ALL CONSTRUCTION MATERIAL AND SEDIMENT. USE APPROPRIATE PERMANENT STABILIZATION METHODS TO STABILIZE BARE AREAS AROUND THE INLET.

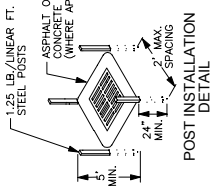

POST INSTALLATION DETAIL

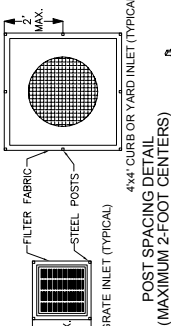

POST SPACING DETAIL (MAXIMUM 2-FOOT CENTERS)

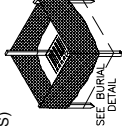

SEED CORRAL DETAIL

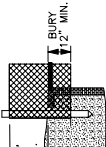

FILTER FABRIC BURIAL DETAIL

TYPE A
LOW FLOW INLET FILTERS
(FILTER FABRIC INLET PROTECTION)

FILTER FABRIC INSTALLATION DETAIL

INSTALLATION:

1. INSTALL SEDIMENT TUBES BY LAYING THEM FLAT ON THE GROUND. CONSTRUCT A SMALL TRENCH TO A DEPTH THAT IS COMPACT THE SEDIMENT TUBE DIAMETER LOW AND INTERFACE. INSTALL ALL SEDIMENT TUBES SO NO GAP EXISTS BETWEEN THE SOIL AND A MINIMUM OF 6 INCHES TO PREVENT FLOW AND SEDIMENT FROM PASSING THROUGH THE FIELD JOINT. NEVER STACK SEDIMENT TUBES ON TOP OF ONE ANOTHER.
2. SHOULD SEDIMENT TUBE BECOME DAMAGED DURING INSTALLATION, PLACE A STAKE ON BOTH SIDES OF THE DAMAGED AREA TERMINATING THE TUBE SEGMENT AND INSTALL A NEW TUBE SEGMENT.
3. SEDIMENT TUBES USING WOODEN STAKES (MINIMUM 4 FEET IN LENGTH, MINIMUM MEASURED DIMENSION 2 INCHES, MAXIMUM MEASURED DIMENSION 7 1/2 OR STEEL POSTS (STANDARD "T" SECTIONS WITH A MINIMUM WEIGHT OF 1.25 POUNDS PER FOOT, MAXIMUM 2-FOOT CENTERS). INSTALL THE STAKES ON THE DOWNSTREAM END OF THE SEDIMENT TUBE. DRIVE THE STAKES INTO THE GROUND TO A MINIMUM DEPTH OF 2 FEET OR TO THE MAXIMUM EXTENT PRACTICABLE.

INSPECTION AND MAINTENANCE:

1. INSPECT SEDIMENT TUBES AFTER INSTALLATION FOR GAPS UNDER THE SEDIMENT TUBE. REPAIR RILLS, COLLIES, AND ALL UNDERCUTTING NEAR SEDIMENT TUBES. SEDIMENT TUBES WILL ALSO BE INSPECTED EVERY SEVEN DAYS AND INSPECTIONS ARE RECOMMENDED AFTER EACH STORM WITH OTHER U.S. AGENCIES.
2. CHANGING CONSTRUCTION SITE CONDITIONS, SEDIMENT TUBES ARE REQUIRED TO ADAPT TO EXCEEDED AS DETERMINED BY THE ENGINEER, INSPECTOR, OR MANUFACTURER'S REPRESENTATIVE.
3. REMOVE ALL SEDIMENT TUBES FROM THE SITE WHEN THE FUNCTIONAL LONGEVITY IS REPRESENTATIVE.
4. DISPOSE OF SEDIMENT TUBES IN REGULAR MEANS AS NON-HAZARDOUS, INERT MATERIAL.

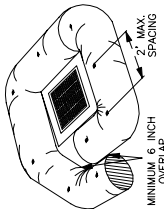
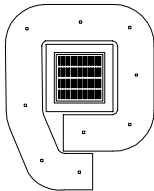

TYPE A
LOW FLOW INLET FILTERS
(SEDIMENT TUBE INLET PROTECTION)

ATTACH FILTER FABRIC TO POSTS WITH HEAVY-DUTY PLASTIC TIES SPACED 6" APART MAX.

FOLD FABRIC TO COVERAP ENDS AND SECURE WITH STAPLES OR WIRE TIES



Greenville County
Storm Water Management

INLET FILTER TYPE A

STANDARD DRAWING NO.

SC-07A

APPROVED BY: GREENVILLE COUNTY STORM WATER MANAGEMENT

January, 2018
DATE

NOTES:

1. DRAWING SHOWS TYPE 16 CATCH BASIN.
2. NON-WEIGHTED TUBES WILL BE INSTALLED IMMEDIATELY AFTER GRADING AND SUBGRADE AND BASE PREPARATION. UNWEIGHTED TUBES WILL BE INSTALLED AFTER GRADING FOR CATCH BASIN TYPES 1, 16, 17, AND 18 WITH DRAINAGE AREAS LESS THAN 1 ACRE.
3. INLET TUBES MAY BE TEMPORARILY MOVED DURING CONSTRUCTION AS NEEDED.
4. NON WEIGHTED SEDIMENT TUBES WILL BE STAKED DOWN WITH 3/4 INCH X 3/4 INCH WOODEN STAKES. MINIMUM DIMENSION 2 1/4 INCH X 3/4 INCH. MAXIMUM DIMENSION 2 INCHES LONG. STAKES SHALL BE PLACED ON THE CENTER OF THE TUBES. STAKES WILL BE DRIVEN INTO THE GROUND TO A MINIMUM OF 2 FEET FOR TO THE MAXIMUM EXTENT PRACTICABLE. INSTALL NON-WEIGHTED TUBES TO ENSURE THAT ALL OVERFLOW OR OVERTOPPING WATER HAS THE ABILITY TO ENTER THE INLET UNOBSTRUCTED.
5. THE STAKES WILL BE INTERVIEWED WITH THE OUTER MESH ONLY AND WILL BE RECOMMENDATIONS FOR OTHER STAKING DETAILS. REFER TO MANUFACTURER'S RECOMMENDATIONS FOR OTHER STAKING DETAILS.
6. AFTER ROAD BASE COURSE IS PLACED, WEIGHTED INLET TUBES WILL BE PLACED FOR CATCH BASIN TYPES 10, 12, 14, 15, 16, 17, & 18. 2 1/4 INCH X 3/4 INCH X 24 INCHES ARE APPLICABLE. WHERE CONSTRUCTION TRAFFIC MAY OCCUR AROUND THE INLET.
7. INSTALL WEIGHTED INLET TUBES LYING FLAT ON THE GROUND WITH NO GAPS BETWEEN THE UNDERLYING SURFACE AND THE TUBE.
8. DO NOT COMPLETELY BLOCK INLETS WITH INLET TUBES. INSTALL WEIGHTED INLET TUBES IN SUCH A MANNER THAT ALL OVERFLOW CAN ENTER THE INLET UNOBSTRUCTED. BETWEEN THE WEIGHTED INLET TUBE AND THE INLET.
9. FOR WEEP HOLE APPLICATIONS, BOTH WEIGHTED AND NON-WEIGHTED INLET TUBES ARE APPLICABLE.
10. ALL WEIGHTED TYPE F INLET STRUCTURE FILTERS ARE APPLICABLE AS TYPE E INLET STRUCTURE FILTERS.
11. REPLACE INLET TUBES DURING INSTALLATION AS DIRECTED BY THE ENGINEER, INSPECTOR, OR MANUFACTURER'S REPRESENTATIVE AT THE CONTRACTOR'S EXPENSE.
12. ALL TYPE F INLET FILTERS WILL BE INSPECTED EVERY 7 CALENDAR DAYS.

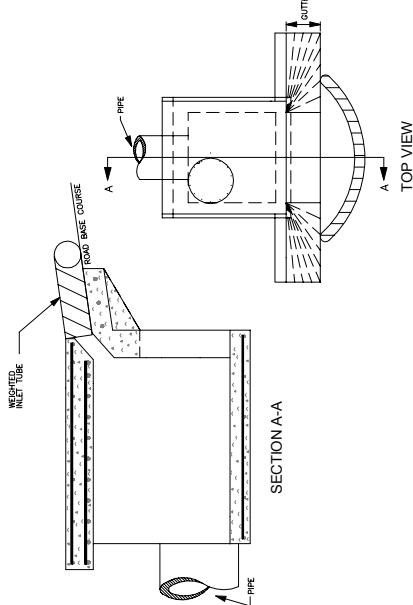

WEIGHTED INLET TUBE

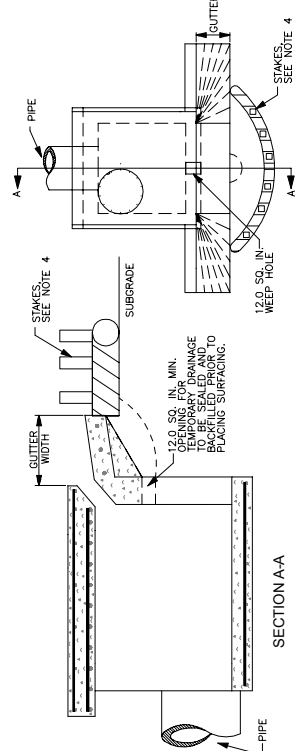

NON-WEIGHTED INLET TUBE

Greenville County
Storm Water Management

INLET FILTER TYPE F

STANDARD DRAWING NO. **SC-07F**

APPROVED BY: **GREENVILLE COUNTY STORM WATER MANAGEMENT** **JANUARY, 2018** DATE

SC-14 CONCRETE WASHOUT

GOOD install but full and needs maintenance



WRONG - plastic liner is poorly secured



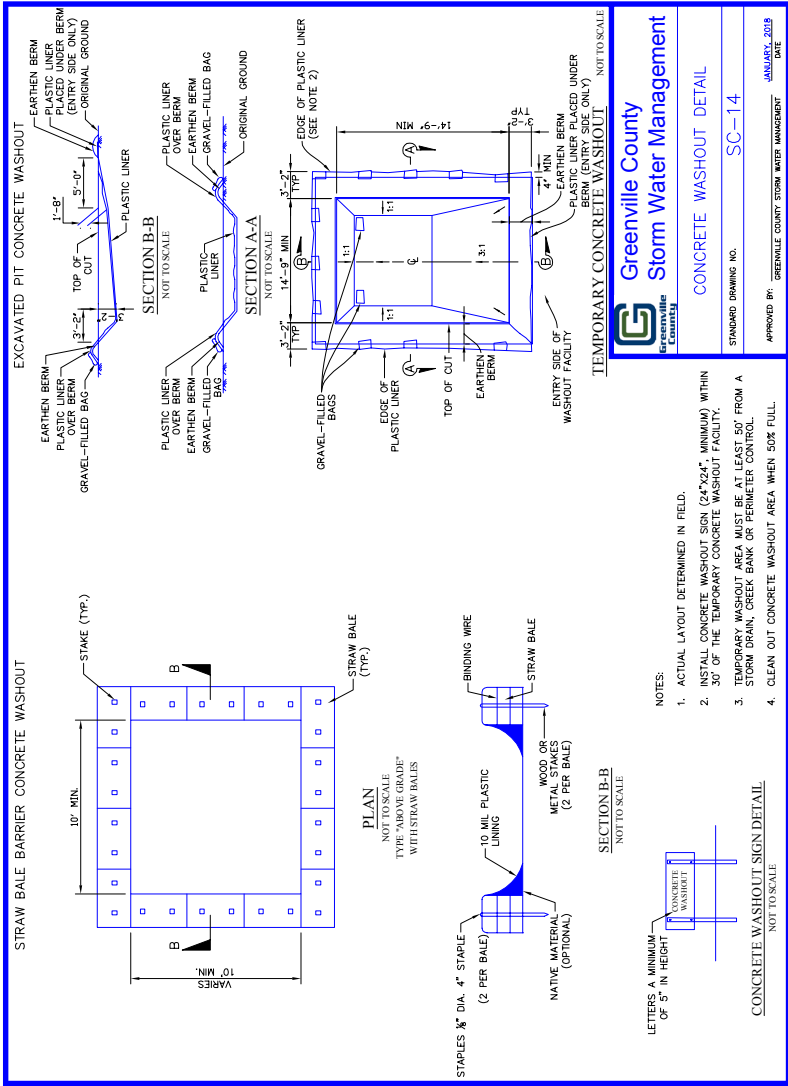

- NOTES:
1. ACTUAL LAYOUT DETERMINED IN FIELD.
 2. INSTALL CONCRETE WASHOUT SIGN (24"x36" MINIMUM) WITHIN 30' OF THE TEMPORARY CONCRETE WASHOUT FACILITY.
 3. TEMPORARY WASHOUT AREA MUST BE AT LEAST 50' FROM A STORM DRAIN, CREEK BANK OR PERIMETER CONTROL.
 4. CLEAN OUT CONCRETE WASHOUT AREA WHEN 50% FULL.

EC-03 SEEDING/STABILIZATION

GOOD - even coverage



WRONG - poor coverage



Final Stabilization

Final Stabilization is defined that all land-disturbing activities at the construction site have been completed and that on all areas not covered by permanent structures, either

- 1 A uniform (e.g., evenly distributed, without large bare areas) permanent vegetative cover with a density of 70 percent has been established, or
- 2 Equivalent permanent stabilization measures (such as the use of landscaping mulch, riprap, pavement, and gravel) have been implemented to provide effective cover for exposed portions of the construction site not stabilized with permanent vegetation.

Acceptance of Permanent Seeding

Before acceptance, a uniform perennial vegetative cover with a density of 70% of each square yard of the seeded area is required. A well developed root system must be established to sufficiently survive dry periods and winter weather and be capable of reestablishment in the spring.

Seeding Dates

Perform seeding during the periods and at the rates specified in the seeding tables. Do not use temporary cover by seeding or permanent seeding for projects when:

- ◆ The ground is frozen and/or when the 10-day forecasted low temperature remains below 35 degrees Fahrenheit;
- ◆ The ground is excessively wet; or
- ◆ The ground is excessively dry (periods of drought) unless watering is specified.
- ◆ During periods of adverse conditions, use temporary cover by mulch.

Seedbed Preparation

- ◆ Ensure that the areas receiving permanent seeding are uniform and conform to the finished grade of the Project.
- ◆ Perform minor shaping and evening of uneven and rough areas outside of the graded area in order to provide for more effective erosion control and for ease of subsequent mowing operations.
- ◆ Loosen the seedbed (including cut slopes) to a minimum depth of three (3) inches before initiating permanent seeding and temporary seeding.
- ◆ An acceptable method of preparing the seedbed on slopes is vertically tracking the seedbed up and seedbed up and down the slope with proper equipment.
- ◆ Remove stones larger than two and one-half (2½) inches in any dimension, large dirt clods, roots, or other debris brought to the surface.
- ◆ Use compost if good seedbed material is not located on site or results of the soil test show the seedbed is excessively nutrient deficient to the extent of requiring costly fertilizer additions and or have excessively low pH values (lower than 5.0).
- ◆ Consider the use of mechanical seed drills to perform permanent seeding on areas where temporary seeding or temporary cover by mulch was previously utilized.

Permanent Seeding Installation

Following the preparation of the seedbed, perform permanent seeding per the seeding Tables and apply an appropriate Mulch within 5 working days and/or prior to a rainfall event that compacts the prepared seedbed. If a rain event occurs that compacts or erodes the seedbed prior to performing permanent seeding, the seedbed must be re-prepared prior to conducting permanent seeding. Add fertilizer and lime as required by a soil test.

Sod

Initiate Sod applications within 7 calendar days where land disturbing activities have permanently ceased on the Project. Initiate Sod applications measures as soon as practicable for areas where initiating Sod applications within 7 days is infeasible (e.g., where snow cover, frozen ground, or drought conditions preclude stabilization). Use Sod on slopes less than 2H:1V.

Acceptance of Sod

Acceptance is contingent on establishing a satisfactory stand of perennial grass. Sod application areas are acceptable when all requirements including maintenance are met and a healthy, evenly colored, viable stand of grass is established. A satisfactory stand of grass must have a root system that is sufficient to survive dry periods and winter weather and is capable of re-establishing in the spring.

Sod

Do not use sodding on slopes steeper than 2H:1V, and if sodding is mowed, do not place on slopes greater than 3H:1V. Install Warm Season Sod between March 1st and September 1st. Install Cool Season Sod anytime during the year as long as the soil is not frozen.

Do not place Sod on:

- ◆ Soil that is frozen and/or when the 10-day forecasted low temperature remains below 35 degrees Fahrenheit;
- ◆ Soil that is excessively wet;
- ◆ Soil that is excessively dry (periods of heat or drought) unless watering is specified;
- ◆ Soil that is composed of compacted clay; and
- ◆ Soil that has been treated with pesticides.

Sod Bed Preparation

- ◆ Ensure the Sod bed is uniform and conforms to the finished grade of the Project.
- ◆ Loosen the Sod Bed to a minimum depth of 3 inches before placing Sod.
- ◆ Furnish and place topsoil or compost in the Sod Bed in areas where the existing Sod Bed has little or no topsoil,
- ◆ Sod when Sod Bed is moist. Moisten dry Sod Beds before sod is laid.

Sod Material

Provide Sod with living, well-established growth, with a dense root mat of predominant grass Specified. Provide vigorous, well rooted, healthy turf, free from disease, insect pests, weeds, other grasses, stones, and any other harmful or detrimental materials.

Sod Installations

Ensure Sod is not installed until the end of the project or when final stabilization is achieved on adjacent areas of the project that drain or discharge to the Sod application.

Amendments

Lime

Agricultural Granular Lime

Use agricultural grade, standard ground limestone for all permanent seeding applications and Sodding applications.

Applying Granular Lime

A soil analysis is recommended prior to application. Apply at a rate within $\pm 10\%$ of weight recommendation of soil analysis. Do not apply more than 2,500 lbs/acre of in a single application.

Fast Acting Lime

Use fast acting liquid and/or dry forms of lime for all temporary seeding and permanent seeding applications.



PAGE INTENTIONALLY LEFT BLANK

PAGE INTENTIONALLY LEFT BLANK



**Greenville
County**

Greenville County Land Development Division
301 University Ridge, Suite S-3300
Greenville, SC 29601
Phone: 864.467.4610 Fax: 864.467.7518
www.greenvillecounty.org/land_development